



# Single/Dual/Quad High-Side Current-Sense Amplifiers with Internal Gain

## General Description

The MAX4376/MAX4377/MAX4378 single, dual, and quad precision high-side current-sense amplifiers are available in space-saving packages. They feature buffered voltage outputs that eliminate the need for gain-setting resistors and are ideal for today's notebook computers, cell phones, and other systems where current monitoring is critical. These precision devices are offered in three fixed-gain versions of 20, 50, and 100:

GAIN	SUFFIX
20	T
50	F
100	H

For example, MAX4376TAUK is a single high-side amplifier with a gain of 20.

High-side current monitoring is especially useful in battery-powered systems since it does not interfere with the ground path of the battery charger. The input common-mode range of 0 to +28V is independent of the supply voltage and ensures that the current-sense feedback remains viable even when connected to a battery pack in deep discharge.

The full-scale current reading can be set by choosing the appropriate voltage gain and external-sense resistor. This capability offers a high level of integration and flexibility, resulting in a simple and compact current-sense solution.

The MAX4376/MAX4377/MAX4378 operate over a supply voltage range of +3V to +28V, draw 1mA of supply current per amplifier, and operate over the full automotive temperature range of -40°C to +125°C. These devices have a wide bandwidth of 2MHz, making them suitable for use inside battery-charger control loops. The buffered outputs drive up to 2mA of output current into a ground-referenced load.

The MAX4376 is available in a tiny 5-pin SOT23 package. The MAX4377/MAX4378 are available in space-saving 8-pin  $\mu$ MAX and 14-pin TSSOP packages, respectively.

## Applications

Notebook Computers	Portable/Battery-Powered Systems
Current-Limited Power Supplies	Cell Phones
Fuel Gauges in PC	Smart Battery Packages
General-System/Board-Level Current Monitoring	Automotive Current Detect
Battery Chargers	Power Management Systems
	PA Bias Control

## Features

- ◆ Low-Cost Single/Dual/Quad High-Side Current-Sense Amplifiers
- ◆  $\pm 0.5\%$  Typical Full-Scale Accuracy
- ◆ +3V to +28V Supply Operation
- ◆ Adjustable Current-Sense Capability with External Sense Resistor
- ◆ Buffered Output Voltage with 2mA Drive
- ◆ 1mA (typ) Supply Current
- ◆ 2.0MHz Bandwidth (Gain = +20V/V)
- ◆ Automotive Temperature Range (-40°C to +125°C)
- ◆ Full 0 to 28V Common-Mode Range, Independent of Supply Voltage
- ◆ Three Gain Versions Available
  - +20V/V (MAX437\_T)
  - +50V/V (MAX437\_F)
  - +100V/V (MAX437\_H)
- ◆ Available in Space-Saving 5-pin SOT23 (Single), 8-pin  $\mu$ MAX (Dual), and 14-pin TSSOP (Quad)

## Ordering Information

PART	GAIN (+V/+V)	TEMP. RANGE	PIN-PACKAGE	TOP MARK
MAX4376TAUK-T	20	-40°C to +125°C	5 SOT23-5	ADOG
MAX4376FAUK-T	50	-40°C to +125°C	5 SOT23-5	ADOH
MAX4376HAUK-T	100	-40°C to +125°C	5 SOT23-5	ADOI
MAX4376TASA	20	-40°C to +125°C	8 SO	—
MAX4376FASA	50	-40°C to +125°C	8 SO	—
MAX4376HASA	100	-40°C to +125°C	8 SO	—

Ordering Information continued at end of data sheet.

## Pin Configurations

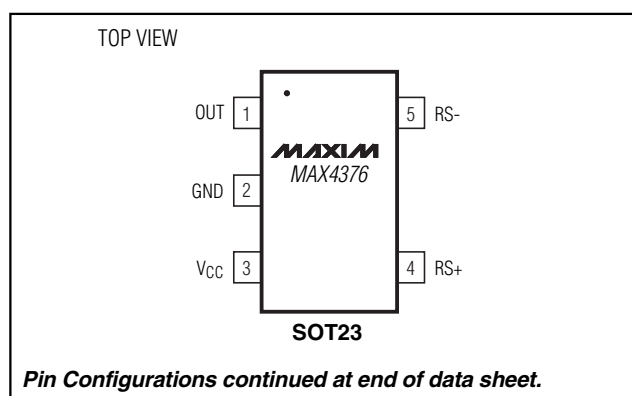

MAX4376/MAX4377/MAX4378

# Single/Dual/Quad High-Side Current-Sense Amplifiers with Internal Gain

## ABSOLUTE MAXIMUM RATINGS

V <sub>CC</sub> , RS+, RS- to GND	-0.3V to +30V	14-pin SO (derate 8.33mW/°C above +70°C)	667mW
OUT to GND	-0.3V to (V <sub>CC</sub> + 0.3V)	14-pin TSSOP (derate 9.1mW/°C above +70°C)	727mW
Differential Input Voltage (V <sub>RS+</sub> - V <sub>RS-</sub> )	±8V	Operating Temperature Range	-40°C to +125°C
Output Short Circuit to V <sub>CC</sub>	Continuous	Junction Temperature	+150°C
Output Short Circuit to GND	1s	Storage Temperature Range	-65°C to +150°C
Current into Any Pin	±20mA	Lead Temperature (soldering, 10s)	+300°C
Continuous Power Dissipation (T <sub>A</sub> = +70°C)			
5-pin SOT23 (derate 7.1mW/°C above +70°C)	571mW		
8-pin μMAX (derate 4.5mW/°C above +70°C)	362mW		
8-pin SO (derate 5.88mW/°C above +70°C)	471mW		

Stresses beyond those listed under "Absolute Maximum Ratings" may cause permanent damage to the device. These are stress ratings only, and functional operation of the device at these or any other conditions beyond those indicated in the operational sections of the specifications is not implied. Exposure to absolute maximum rating conditions for extended periods may affect device reliability.

## ELECTRICAL CHARACTERISTICS

(V<sub>RS+</sub> = 0 to 28V, V<sub>SENSE</sub> = (V<sub>RS+</sub> - V<sub>RS-</sub>) = 0, V<sub>CC</sub> = +3.0V to +28V, R<sub>L</sub> = ∞, T<sub>A</sub> = T<sub>MIN</sub> to T<sub>MAX</sub>, unless otherwise noted. Typical values are at T<sub>A</sub> = 25°C.) (Note 1)

PARAMETER	SYMBOL	CONDITIONS	MIN	TYP	MAX	UNITS	
Operating Voltage Range	V <sub>CC</sub>	Guaranteed by PSR test	3		28	V	
Common-Mode Input Range	V <sub>CM</sub>	Guaranteed by total OUT voltage error test	0		28	V	
Common-Mode Rejection	CMR	2V ≤ V <sub>RS+</sub> ≤ 28V, V <sub>SENSE</sub> = 100mV		90		dB	
Supply Current per Amplifier	I <sub>CC</sub>	V <sub>SENSE</sub> = 5mV, V <sub>RS+</sub> > 2.0V, V <sub>CC</sub> = 12V		1	2.2	mA	
Leakage Current	I <sub>RS+</sub> , I <sub>RS-</sub>	V <sub>CC</sub> = 0, V <sub>RS+</sub> = 28V			8	μA	
Input Bias Current	I <sub>RS+</sub>	V <sub>RS+</sub> > 2.0V	0		60	μA	
		V <sub>RS+</sub> ≤ 2.0V	-400		60		
	I <sub>RS-</sub>	V <sub>RS+</sub> > 2.0V	0		120		
		V <sub>RS+</sub> ≤ 2.0V	-800		120		
Full-Scale Sense Voltage	V <sub>SENSE</sub>			150		mV	
Total OUT Voltage Error (Note 2)		I <sub>OUT</sub> ≤ 2mA	V <sub>SENSE</sub> = 100mV, V <sub>CC</sub> = 12V, V <sub>RS+</sub> = 12V			±6.75	%
			V <sub>SENSE</sub> = 100mV, V <sub>CC</sub> = 12V, T <sub>A</sub> = +25°C		±0.5	±3.25	
			V <sub>SENSE</sub> = 100mV, V <sub>CC</sub> = 28V, V <sub>RS+</sub> = 28V			±11	
			V <sub>SENSE</sub> = 100mV, V <sub>CC</sub> = 28V, V <sub>RS+</sub> = 28V, T <sub>A</sub> = +25°C		±0.5	±5	
			V <sub>SENSE</sub> = 100mV, V <sub>CC</sub> = 12V, V <sub>RS+</sub> = 0.1V		±9	±32	
			V <sub>SENSE</sub> = 6.25mV, V <sub>CC</sub> = 12V, V <sub>RS+</sub> = 12V (Note 3)		±7		
OUT High Voltage (Note 4)	(V <sub>CC</sub> - V <sub>OUT</sub> )	V <sub>CC</sub> = 3V, I <sub>OUT</sub> = 2mA		0.9	1.2	V	
OUT Low Voltage	V <sub>OL</sub>	I <sub>OUT</sub> = 200μA, V <sub>CC</sub> = 3V, V <sub>SENSE</sub> = 0		30		mV	

# Single/Dual/Quad High-Side Current-Sense Amplifiers with Internal Gain

MAX4376/MAX4377/MAX4378

## ELECTRICAL CHARACTERISTICS (continued)

( $V_{RS+} = 0$  to 28V,  $V_{SENSE} = (V_{RS+} - V_{RS-}) = 0$ ,  $V_{CC} = +3.0V$  to +28V,  $R_L = \infty$ ,  $T_A = T_{MIN}$  to  $T_{MAX}$ , unless otherwise noted. Typical values are at  $T_A = 25^\circ C$ .) (Note 1)

PARAMETER	SYMBOL	CONDITIONS		MIN	TYP	MAX	UNITS	
Bandwidth	BW	$V_{CC} = 12V$ $V_{RS+} = 12V$ $C_{LOAD} = 15pF$	$V_{SENSE} = 100mV$ (gain = +20V/V)		2		MHz	
			$V_{SENSE} = 100mV$ (gain = +50V/V)		1.7			
			$V_{SENSE} = 100mV$ (gain = +100V/V)		1.2			
			$V_{SENSE} = 6.25mV$ (Note 3)		0.5			
Slew Rate	SR	$V_{SENSE} = 20mV$ to 100mV, $C_{LOAD} = 15pF$			10		V/ $\mu s$	
Gain	$A_V$	MAX437_T			+20		V/V	
		MAX437_F			+50			
		MAX437_H			+100			
Gain Accuracy	$\Delta A_V$	$V_{SENSE} = 10mV$ to 150mV, $V_{CC} = 12V$ , $I_{OUT} = 2mA$ , gain = 20 and 50	$T_A = T_{MIN}$ to $T_{MAX}$			$\pm 5.5$	%	
			$T_A = +25^\circ C$		$\pm 0.5$	$\pm 2.5$		
		$V_{SENSE} = 10mV$ to 150mV, $V_{CC} = 20V$ , $I_{OUT} = 2mA$ , gain = 100	$T_A = T_{MIN}$ to $T_{MAX}$			5.5		
			$T_A = +25^\circ C$		$\pm 0.5$	$\pm 2.5$		
OUT Setting Time to 1% of Final Value		$V_{CC} = 12V$ , $V_{RS+} = 12V$ , $C_{LOAD} = 15pF$	$V_{SENSE} = 6.25mV$ to 100mV		400		ns	
			$V_{SENSE} = 100mV$ to 6.25mV		800			
Maximum Capacitive Load	$C_{LOAD}$	No sustained oscillation			1000		pF	
Output Resistance	$R_{OUT}$	$V_{SENSE} = 100mV$			5		$\Omega$	
Power-Supply Rejection	PSR	$V_{RS+} > 2V$ , $V_{OUT} = 1.6V$ , $V_{CC} = 3V$ to 28V		66	90		dB	
Power-Up Time to 1% of Final Value		$V_{SENSE} = 100mV$ , $C_{LOAD} = 15pF$			2		$\mu s$	
Saturation Recovery Time to 1% of Final Value		$V_{CC} = 12V$ , $V_{RS+} = 12V$ , $C_{LOAD} = 15pF$ , $V_{SENSE} = 100mV$			1		$\mu s$	
Reverse Recovery Time to 1% of Final Value		$V_{CC} = 12V$ , $V_{RS-} = 12V$ , $C_{LOAD} = 15pF$ , $V_{SENSE} = -100mV$ to +100mV			1		$\mu s$	

**Note 1:** All devices are 100% production tested at  $T_A = +25^\circ C$ . All temperature limits are guaranteed by design.

**Note 2:** Total OUT Voltage Error is the sum of gain and offset errors.

**Note 3:** 6.25mV = 1/16 of 100mV full-scale sense voltage.

**Note 4:**  $V_{SENSE}$  such that  $V_{OUT}$  is in saturation.

# Single/Dual/Quad High-Side Current-Sense Amplifiers with Internal Gain

## Typical Operating Characteristics

( $V_{CC} = V_{RS+} = 12V$ ,  $V_{SENSE} = 100mV$ ,  $T_A = +25^{\circ}C$ .)

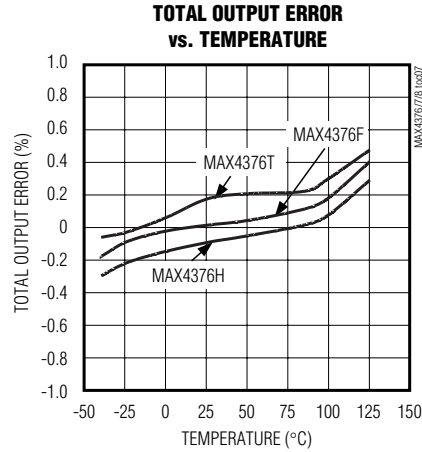
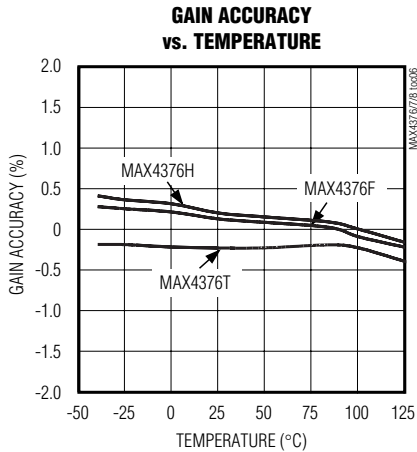
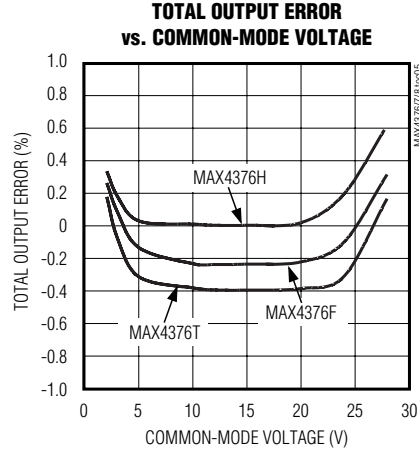
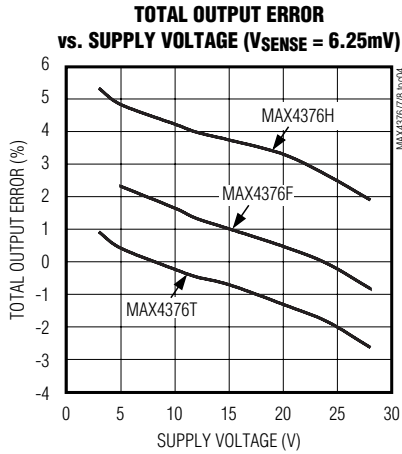
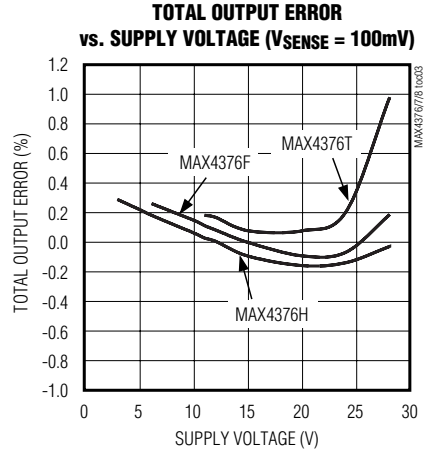
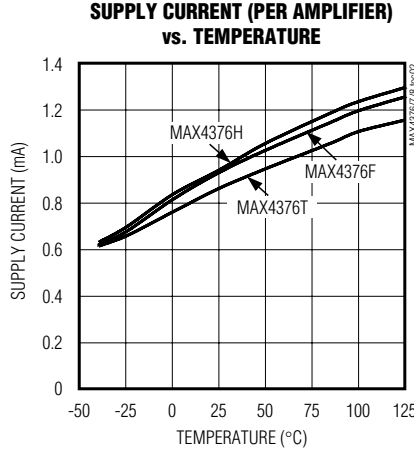
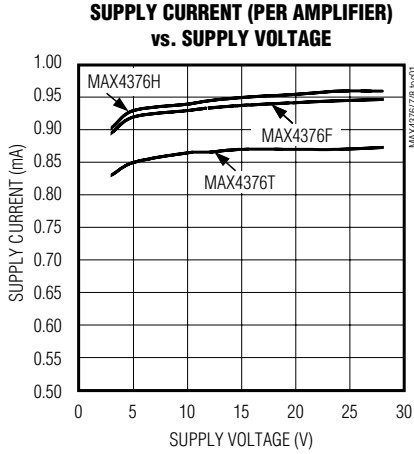

# Single/Dual/Quad High-Side Current-Sense Amplifiers with Internal Gain

## Typical Operating Characteristics (continued)

( $V_{CC} = V_{RS+} = 12V$ ,  $V_{SENSE} = 100mV$ ,  $T_A = +25^{\circ}C$ .)

MAX4376/MAX4377/MAX4378

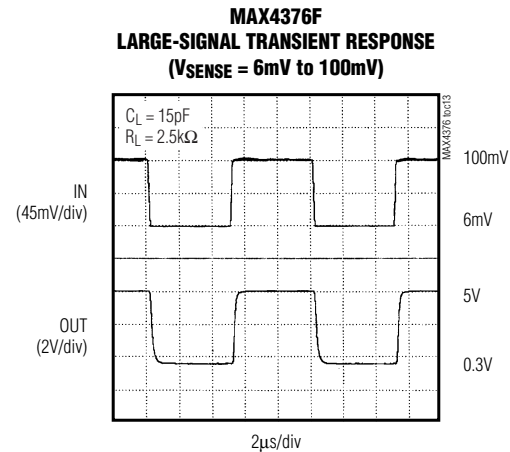
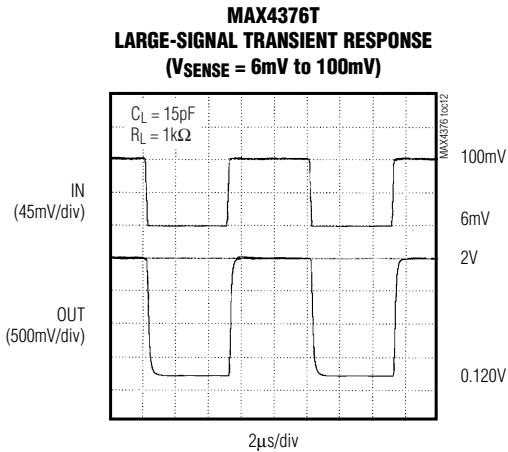
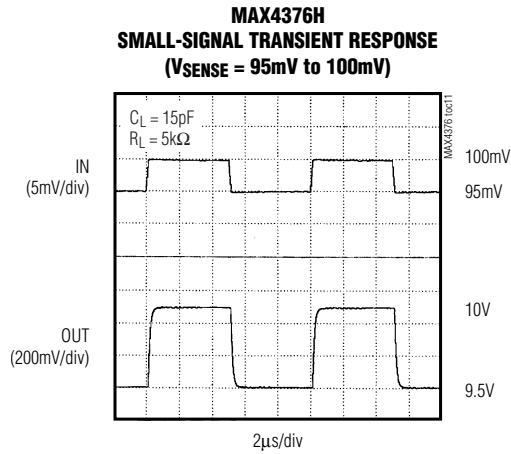
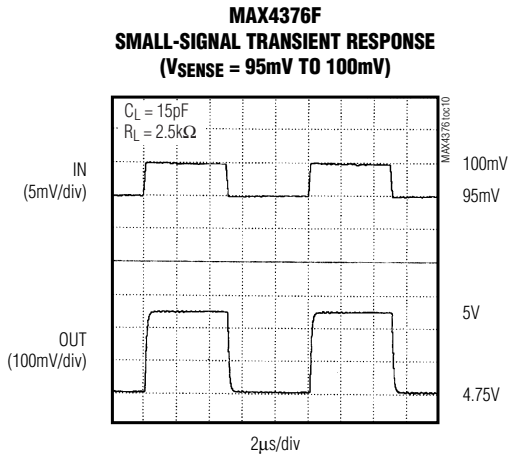
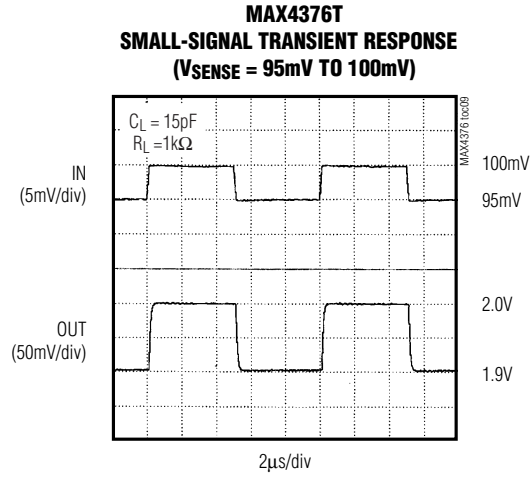
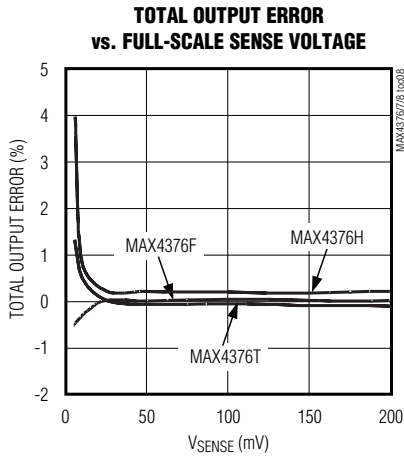

# Single/Dual/Quad High-Side Current-Sense Amplifiers with Internal Gain

## Typical Operating Characteristics (continued)

( $V_{CC} = V_{RS+} = 12V$ ,  $V_{SENSE} = 100mV$ ,  $T_A = +25^{\circ}C$ .)

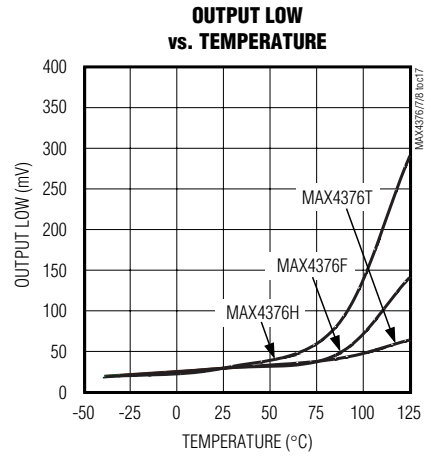
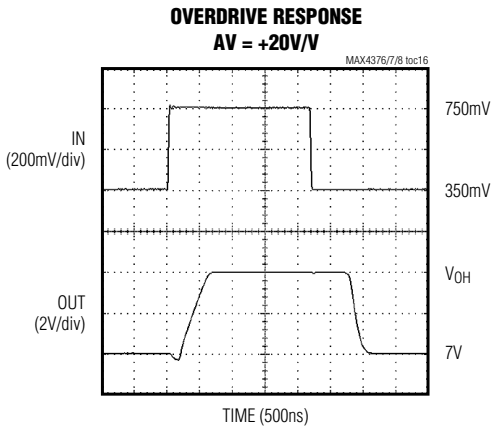
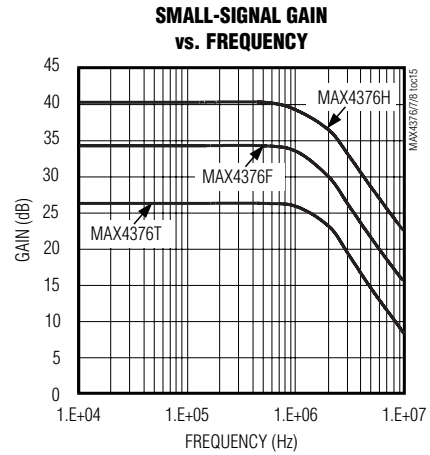
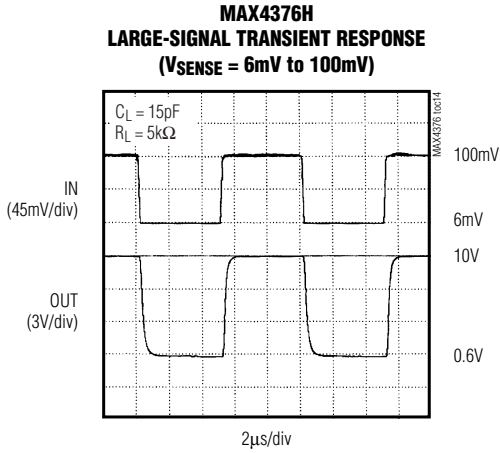

# Single/Dual/Quad High-Side Current-Sense Amplifiers with Internal Gain

## Pin Description

PIN				NAME	FUNCTION
MAX4376	MAX4376	MAX4377	MAX4378		
SOT23-5	SO-8	μMAX-8/ SO-8	SO-14/ TSSOP-14		
1	4	1, 7	1, 7, 8, 14	OUT, OUT_	Output Voltage. $V_{OUT}$ is proportional to the magnitude of the sense voltage ( $V_{RS+} - V_{RS-}$ ). $V_{OUT}$ is approximately zero when $V_{RS-} > V_{RS+}$ (no phase reversal).
2	3	4	11	GND	Ground
3	1	8	4	VCC	Supply Voltage
4	8	3, 5	3, 5, 10, 12	RS+, RS_+	Power connection to the external sense resistor
5	6	2, 6	2, 6, 9, 13	RS-, RS_-	Load-side connection to the external sense resistor
—	2, 5, 7	—	—	N.C.	No Connection. Not internally connected.

## Detailed Description

The MAX4376/MAX4377/MAX4378 high-side current-sense amplifiers feature a 0 to +28V input common-mode range that is independent of supply voltage. This feature allows the monitoring of current out of a battery in deep discharge and also enables high-side current sensing at voltages greater than the supply voltage (VCC).

The MAX4376/MAX4377/MAX4378 operate as follows: current from the source flows through RSENSE to the load (Figure 1). Since the internal sense amplifier's inverting input has high impedance, negligible current flows through RG2 (neglecting the input bias current). Therefore, the sense amplifier's inverting-input voltage equals  $V_{SOURCE} - (I_{LOAD})(R_{SENSE})$ .

The amplifier's open-loop gain forces its noninverting input to the same voltage as the inverting input. Therefore, the drop across RG1 equals  $(I_{LOAD})(R_{SENSE})$ . Since  $I_{RG1}$  flows through RG1,  $I_{RG1} = (I_{LOAD})(R_{SENSE})/RG1$ . The internal current mirror multiplies  $I_{RG1}$  by a current gain factor,  $\beta$ , to give  $I_{RGD} = \beta \times I_{RG1}$ . Solving  $I_{RGD} = \beta \times (I_{LOAD})(R_{SENSE})/RG1$ . Therefore:

$$V_{OUT} = \beta \times (RGD/RG1)(R_{SENSE} \times I_{LOAD}) \times \text{amp gain}$$

where amp gain is 2, 5, or 10.

The part's gain equals  $(\beta \times RGD / RG1) \times \text{amp gain}$ .

Therefore:

$$V_{OUT} = (\text{GAIN})(R_{SENSE})(I_{LOAD})$$

where GAIN = 20 for MAX437\_T.

GAIN = 50 for MAX437\_F.

GAIN = 100 for MAX437\_H.

Set the full-scale output range by selecting RSENSE and the appropriate gain version of the MAX4376/MAX4377/MAX4378.

## Applications Information

### Recommended Component Values

The MAX4376/MAX4377/MAX4378 sense a wide variety of currents with different sense resistor values. Table 1 lists common resistor values for typical operation of the MAX4376/MAX4377/MAX4378.

### Choosing RSENSE

To measure lower currents more accurately, use a high value for RSENSE. The high value develops a higher sense voltage that reduces offset voltage errors of the internal op amp.

In applications monitoring very high currents, RSENSE must be able to dissipate the  $I^2R$  losses. If the resistor's rated power dissipation is exceeded, its value may drift or it may fail altogether, causing a differential voltage across the terminals in excess of the absolute maximum ratings.

If ISENSE has a large high-frequency component, minimize the inductance of RSENSE. Wire-wound resistors have the highest inductance, metal-film resistors are somewhat better, and low-inductance metal-film resistors are best suited for these applications.

### Bidirectional Current-Sense Amplifier

Systems such as laptop computers and other devices that have internal charge circuitry require a precise bidirectional current-sense amplifier to monitor accurately the battery's current regardless of polarity. Figure 2 shows the MAX4377 used as a bidirectional current

# Single/Dual/Quad High-Side Current-Sense Amplifiers with Internal Gain

**Table 1. Recommended Component Values**

FULL-SCALE LOAD CURRENT, $I_{LOAD}$ (A)	CURRENT-SENSE RESISTOR, $R_{SENSE}$ (m $\Omega$ )	GAIN (+V/V)	FULL-SCALE OUTPUT VOLTAGE (FULL-SCALE $V_{SENSE} = 100$ mV), $V_{OUT}$ (V)
0.1	1000	20	2.0
		50	5.0
		100	10.0
1	100	20	2.0
		50	5.0
		100	10.0
5	20	20	2.0
		50	5.0
		100	10.0
10	10	20	2.0
		50	5.0
		100	10.0

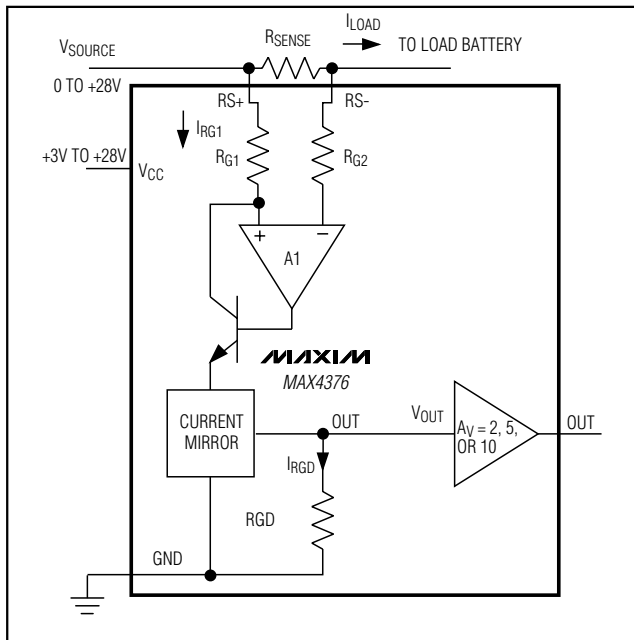

Figure 1. Functional Diagram

monitor. This is useful for implementing either smart battery packs or fuel gauges.

### Current Source Circuit

Figure 3 shows a block diagram using the MAX4376 with a switching regulator to make a current source.

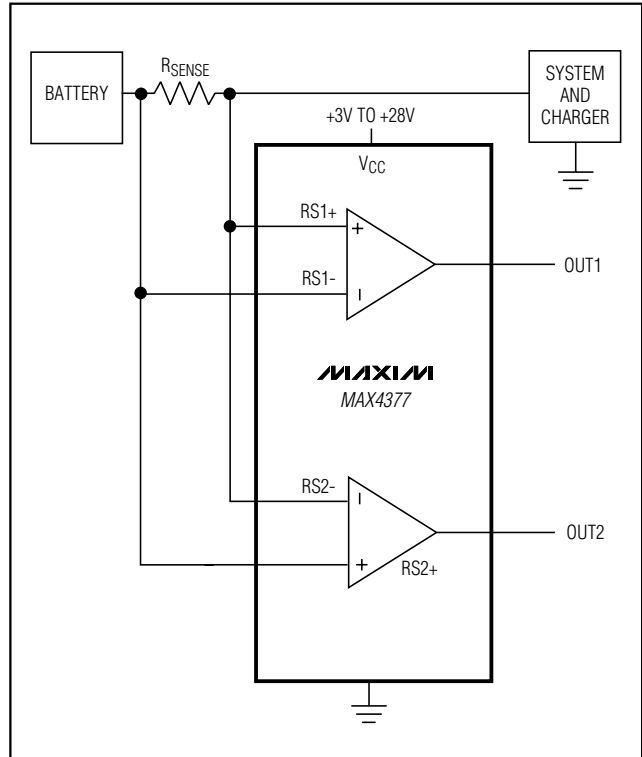

Figure 2. Bidirectional Current Monitor

# Single/Dual/Quad High-Side Current-Sense Amplifiers with Internal Gain

MAX4376/MAX4377/MAX4378

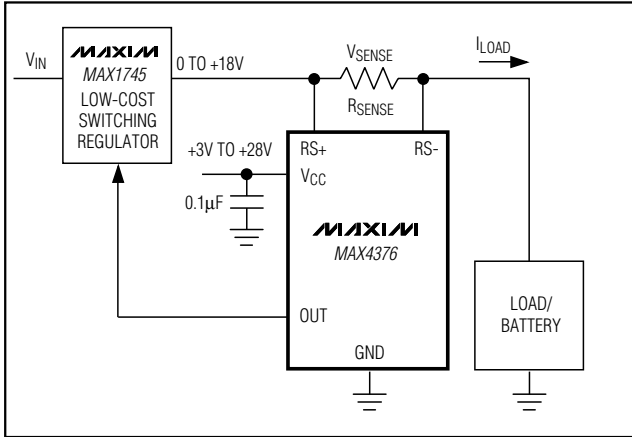
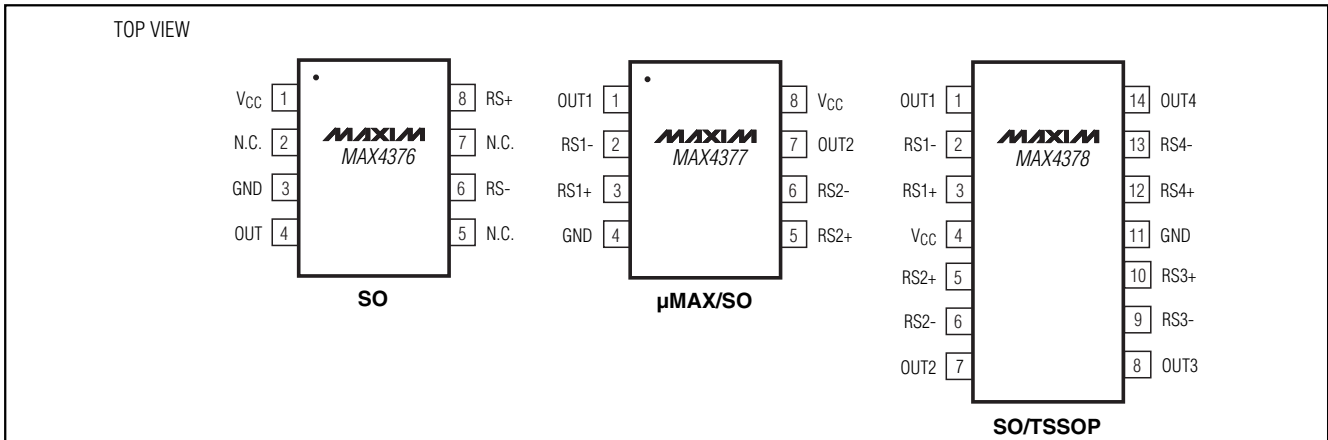

Figure 3. Current Source

## Chip Information

TRANSISTOR COUNT: MAX4376\_: 162  
 MAX4377\_: 324  
 MAX4378\_: 648  
 PROCESS: BiCMOS

## Pin Configurations (continued)



## Ordering Information (continued)

PART	GAIN (+V/+V)	TEMP. RANGE	PIN-PACKAGE	TOP MARK
MAX4377TAUA	20	-40°C to +125°C	8 µMAX	—
MAX4377FAUA	50	-40°C to +125°C	8 µMAX	—
MAX4377HAUA	100	-40°C to +125°C	8 µMAX	—
MAX4377TASA	20	-40°C to +125°C	8 SO	—
MAX4377FASA	50	-40°C to +125°C	8 SO	—
MAX4377HASA	100	-40°C to +125°C	8 SO	—
MAX4378TAUD	20	-40°C to +125°C	14 TSSOP	—
MAX4378FAUD	50	-40°C to +125°C	14 TSSOP	—
MAX4378HAUD	100	-40°C to +125°C	14 TSSOP	—
MAX4378TASD	20	-40°C to +125°C	14 SO	—
MAX4378FASD	50	-40°C to +125°C	14 SO	—
MAX4378HASD	100	-40°C to +125°C	14 SO	—

## Typical Operating Circuit

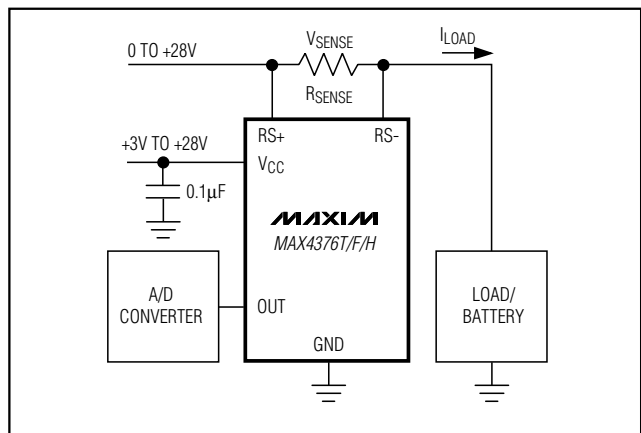

Maxim cannot assume responsibility for use of any circuitry other than circuitry entirely embodied in a Maxim product. No circuit patent licenses are implied. Maxim reserves the right to change the circuitry and specifications without notice at any time.

9 Maxim Integrated Products, 120 San Gabriel Drive, Sunnyvale, CA 94086 408-737-7600

This datasheet has been downloaded from:

[www.DatasheetCatalog.com](http://www.DatasheetCatalog.com)

Datasheets for electronic components.